



A range of diesel engine RPM indicators with the added benefit of an integrated hourmeter. Available with alternator and inductive (flywheel ring gear) signal input.

Model	Bezel	Range
IQHB-BB-4KL	Plastic	0 - 4000 rpm
IQHB-BS-4KL	Stainless	0 - 4000 rpm

IQHB-BB-4KL

IQHB-BS-4KL

Code numbers

IQHB-BB-4KL, IQHB-BS-4KL.

Input voltage

universal connection 9-32VDC;

Operating voltage

12 VDC - default;
 - Compatible also with 24V for stepping motor and LCD type gauges;
 - Require an extra resistor to work with 24V for cross coil type gauge;

Material

316 stainless steel bezel with curved glass;

Protection

IP67 protection rating for the whole gauge;
 can work up to 1m underwater;

Features

Suitable for alternator and inductive (flywheel ring gear) signal input;
 Excellent anti-fogging performance;
 Easy installation with multi-plug socket connection design;

Backlight

red or yellow.

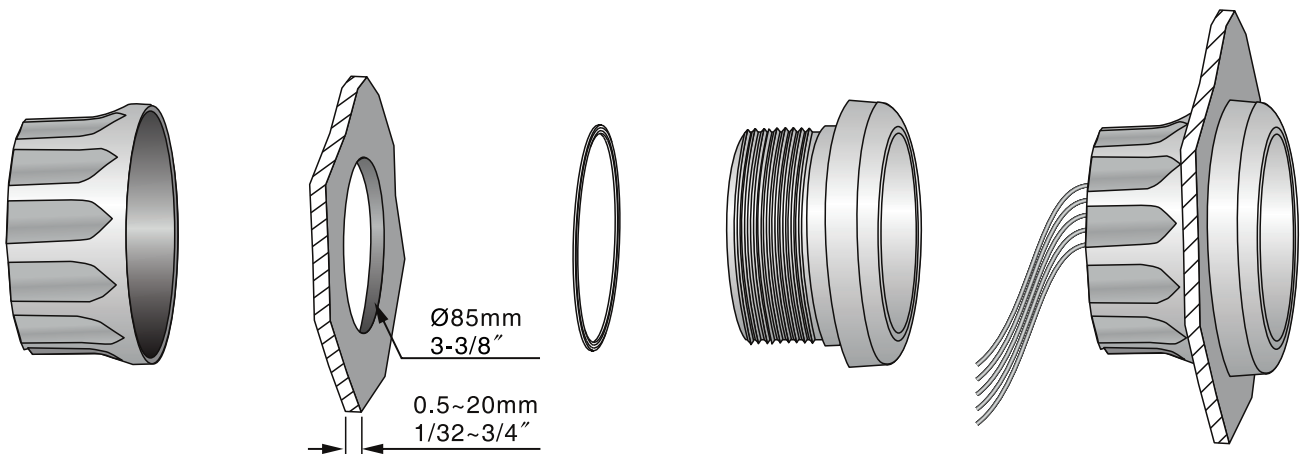

Proudly distributed by:



16 Parkinson Lane
 O'Connor WA 6163
 Australia

Phone +61 8 9331 3100
Fax +61 8 9331 5150
Email mail@amelec.com.au
Web www.amelec.com.au