



IPFR-BB



IPFR-BS

A range of gauges for monitoring fuel tank levels. These units utilise various types of sender units for a variety of mediums including petrol, diesel and fuel oil. Popular for auxiliary tanks in vehicles.

Model	Resistance	Bezel	Range
IPFR-BB	0-190 Ohms	Plastic	E - F
UPFR-BB	240-30 Ohms	Plastic	E - F
IPFR-BS	0-190 Ohms	Stainless	E - F
UPFR-BS	240-30 Ohms	Stainless	E - F

Code numbers

IPFR-BB, UPFR-BB, IPFR-BS, UPFR-BS.

Operating voltage

12 VDC - default;

- Compatible also with 24V for stepping motor and LCD type gauges;
- Require an extra resistor to work with 24V for cross coil type gauge;

Material

316 stainless steel bezel with curved glass;

Protection

IP67 protection rating for the whole gauge;

can work up to 1m underwater;

Features

Excellent anti-fogging performance;

Easy installation with multi-plug socket connection design;

Backlight

red or yellow.

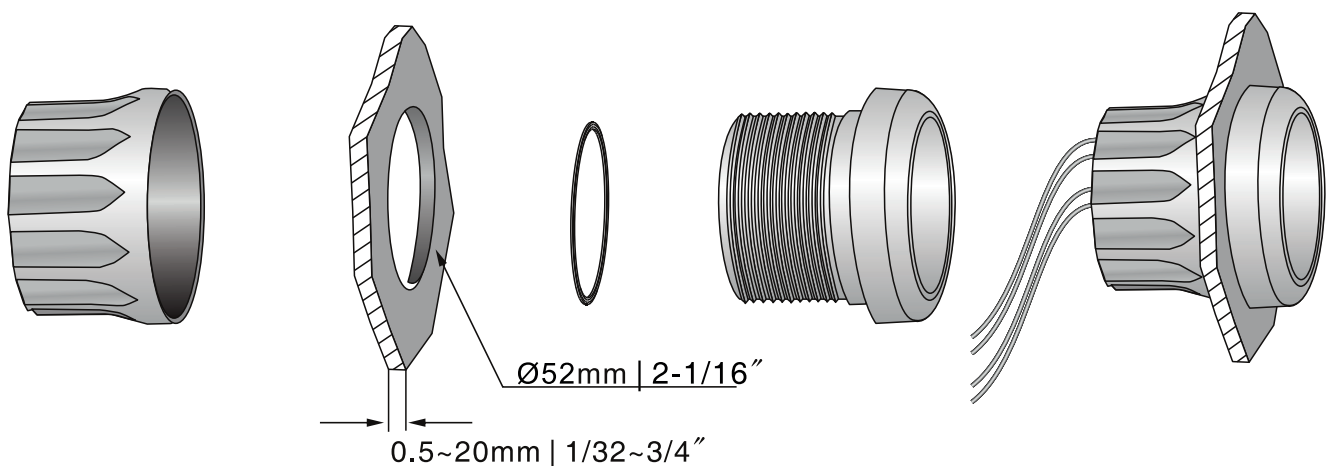

Proudly distributed by:



16 Parkinson Lane
O'Connor WA 6163
Australia

Phone +61 8 9331 3100
Fax +61 8 9331 5150
Email mail@amelec.com.au
Web www.amelec.com.au