



Battery Master Switch Single Pole 150A



CODE NUMBER:

500008 - Stainless steel

GENERAL

Removable handle with weather protection.

ELECTRICAL

Rated Voltage: 48VDC maximum
 Rated Current: 150/1000 Amps sustained/5 secs
 Configuration: Normally Open (N/O)

PHYSICAL

Termination: M10 copper studs
 Stud Torque: 15 ± 1.0 Nm
 Contacts: Copper
 Hardware: Brass nuts and washers
 Construction: 304 stainless steel body and handle
 Environmental: IP63
 Operating Temp: -40°C to +85°C
 Dimensions: 78mmL x 65mmW x 86mmH
 Weight (nominal): 255 Grams with handle and chain

These quality metal switches are ideal for use in vehicles, materials handling, agricultural and industrial equipment applications, etc. Available in zinc plated steel for general use and stainless steel for marine or corrosive environments.

SPARE PARTS

Handle: Order no. 520002
 Boot, chain and strap: Order no. 520024
 Boot and strap: Order no. 520004

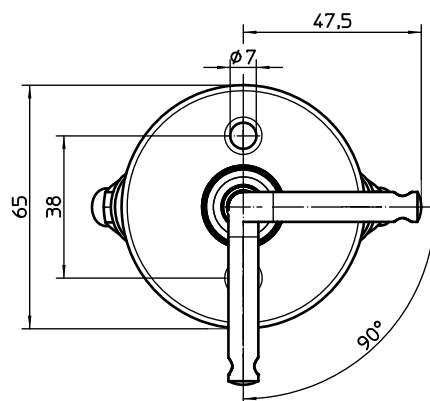
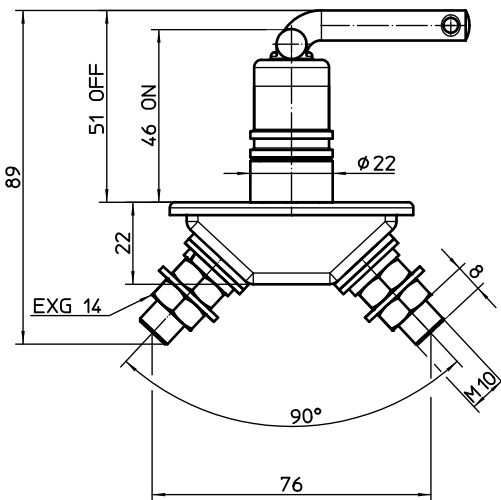

Connection

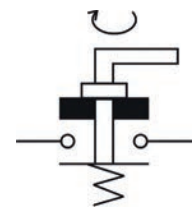

Fixing

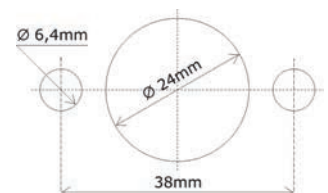

Proudly distributed by:



16 Parkinson Lane
 O'Connor WA 6163
 Australia

Phone +61 8 9331 3100
Fax +61 8 9331 5150
Email mail@amelec.com.au
Web www.amelec.com.au